

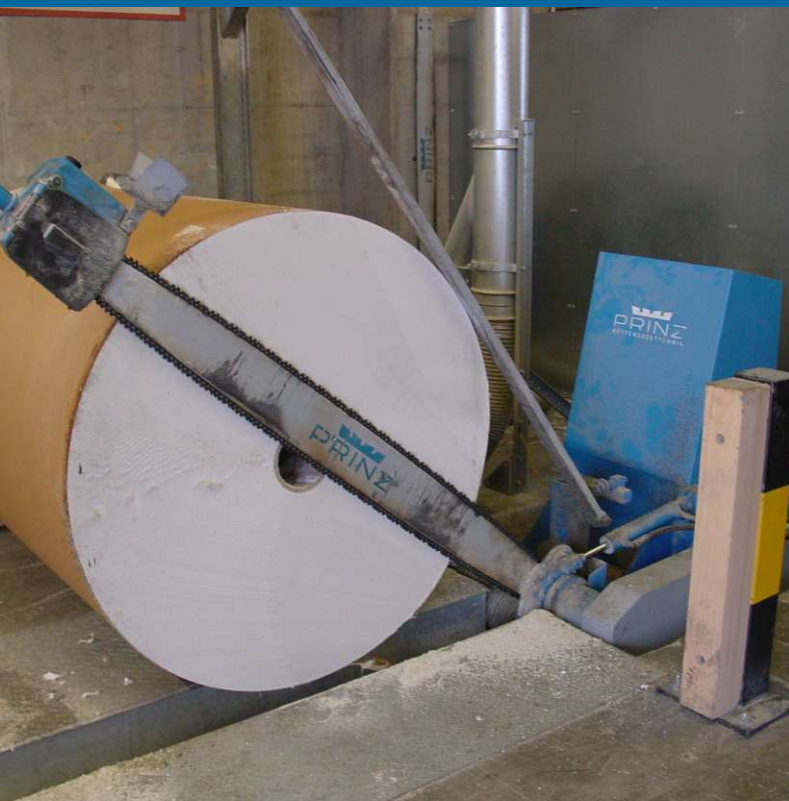

  
**PRINZ**  
KETTENSÄGETECHNIK

**PAPERCUT AND LOGSTAR**  
SAWS FOR PAPER ROLLS CUTTING

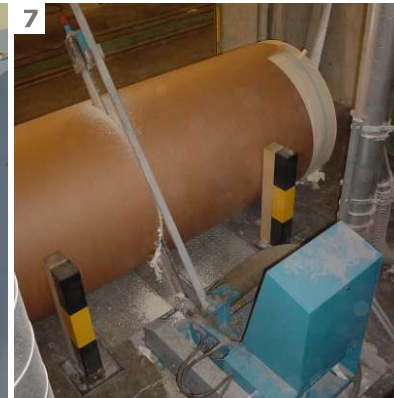

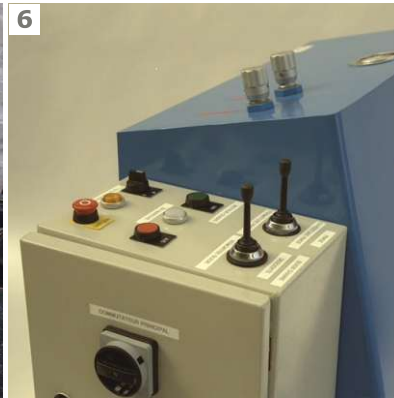
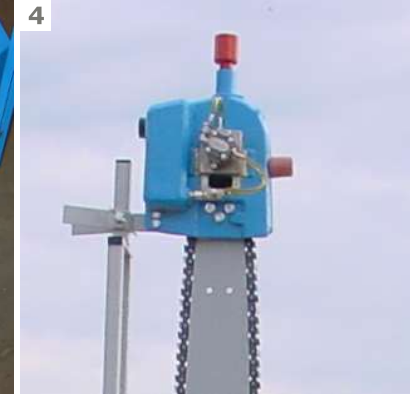
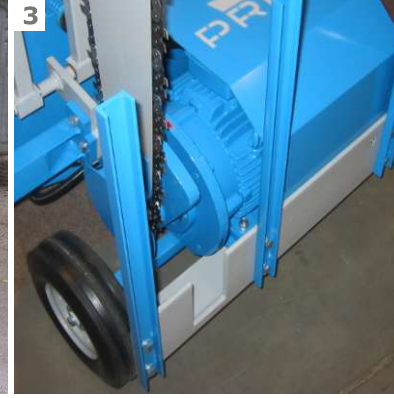

### PAPERCUT ADVANTAGES

- Efficient cross-cutting without necessity of material movement.
- Simple, one-man, manual operation, easy manoeuvring and high cutting stability due to full-tire wheels (photo 1), weight: approx. 170 kg.
- Twin stabilizers preventing deviations of the guide bar and protecting the operator. While aligning the material endings, one stabilizer stiffens the guide bar and increases the cutting accuracy (photo 2).
- Wide front plate for easy perpendicular positioning of the machine relative to the material, height: 750mm (photo 3).
- Rail head chain tensioner that prevents chain breaks, easy chain tension, automatic chain lubrication, precise regulation of oil dose due to gear pump (photo 4).

### LOGSTAR ADVANTAGES

- Electro-hydraulic saw, dedicated to efficient cutting of paper rolls of big diameters.
- Smooth and even material surface after cutting thanks to carbide tipped chains DURACUT with special links geometry (photo 5).
- Hydraulic cut feed, functional steering console (photo 6).
- Massive construction, saw chain drive through the belt transmission, stabilizer for better guiding of cutting unit (photo 7).
- Optionally: hydraulic movable base for the saw, turntable for rolls of big diameters, significantly speeds up the cutting process and extends service life of cutting unit parts.

**PAPERCUT**  
mobile saw



**LOGSTAR**  
stationary saw



## DRAFT WITH DIMENSIONS

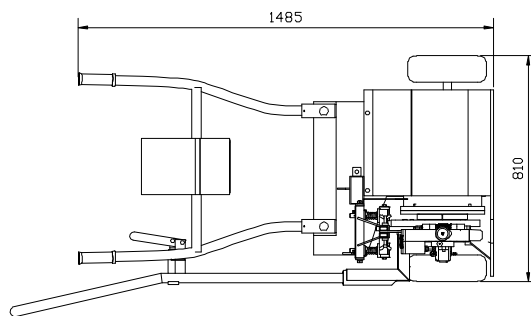
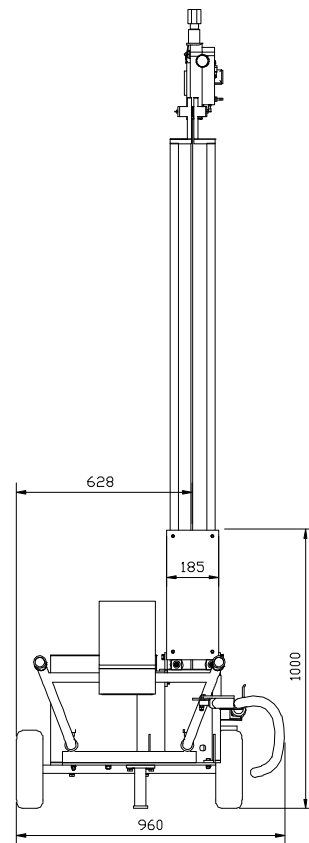
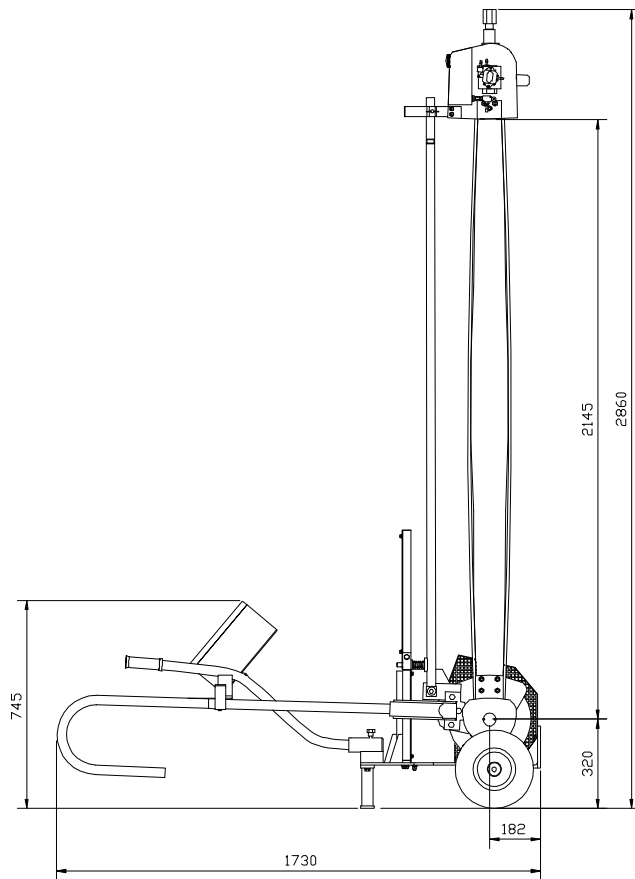

### PAPERCUT mobile saw

dimensions in mm  
modifications reserved

## APPLICATION

efficient cross-cutting  
of paper rolls of big diameters

## TECHNICAL DATA

saw drive	manual
cut feed	manual
cutting engine	3x400 V/50 Hz/7,5 or 11 kW/1400 rpm
max. roll diameter	130cm
guide bar lengths	100, 120, 150, 170, 200cm
cutting accuracy	+/- 4mm
guiding of the cut	2 stabilizers
cutting performance (Ø100cm, turntable)	approx. 6min
lubrication system	gear oil pump
control system	aut. star delta contactor
measuring device	-

## PAPERCUT

## LOGSTAR

stationary saw
hydraulic
15 kW/1400 rpm
160cm
as PAPERCUT
+/- 4mm
1 stabilizer
approx. 5min
as PAPERCUT
as PAPERCUT
-



For paper rolls cutting we use special, carbide tipped chain DURACUT 15/3. 8mm long cutting edge and scraper type for smooth and even surface after cutting. Guide bars are available with one or both sides stellite plating, ensuring the longest endurance. All cutting unit parts are produced in PRINZ, Austria.

For fast and accurate sharpening of saw chains, we recommend manual sharpening device JOLLY or fully automatic SA6.

For easy and quick saw chain repair or shortening of the elongated chain, we recommend rivet breaking and riveting devices.

## all from one source: machine, cutting unit parts, service

As a leading Austrian company in chainsaw technology, PRINZ has been developing and producing crosscut saws, accessories and wearing parts for professional use since 1947. Parts like saw chains, guide bars, chain drive sprockets, pulleys are appropriate for all this kind of machines available on the market.

Machines and accessories made by PRINZ are sold successfully throughout the world. PRINZ endorses an export quota of more than 90%. In the Central and Eastern Europe, PRINZ Polska - established in 1996 - offers complex customer service. The company from Poznan (PL) provides among others guarantee and post-guarantee services, as well as the spare parts storehouse.

  
**PRINZ**  
KETTENSÄGETECHNIK

**PRINZ Polska sp. z o.o.**  
Chainsaw technology

PL 60-175 Poznań, Tulipanowa 4  
tel. +48 61 863 80 88, 98  
fax +48 61 863 80 99  
[www.prinz-polska.com.pl](http://www.prinz-polska.com.pl)  
[info@prinz-polska.com.pl](mailto:info@prinz-polska.com.pl)



partner: